

# Route 36

# Lamar



**MONDAY – FRIDAY • OUTBOUND FROM DOWNTOWN**

	<b>1</b>	<b>2</b>	<b>3</b>	<b>4</b>	<b>5</b>	<b>6</b>	<b>7</b>	<b>8</b>	<b>9</b>
	Hudson Transit Center	Lamar Ave at Bellevue Blvd	Lamar Ave at S Parkway	Knight Arnold Rd at Julius Lewis	Kimball Ave at Highland St	American Way Transit Center	American Way at Perkins Rd	Hickory Ridge Mall	Centennial Dr at Hacks Cross Rd
<b>AM</b>	4:21	4:35	4:40	-----	4:51	5:01	5:09	5:26	5:41
	4:51	5:05	5:10	5:21	-----	5:31	5:39	5:56	6:11
	5:21	5:35	5:40	-----	5:51	6:01	6:09	6:26	6:41
	5:51	6:05	6:10	6:21	-----	6:31	6:39	6:56	7:11
	6:21	6:35	6:40	-----	6:51	7:01	7:09	7:26	7:41
	6:51	7:05	7:10	7:21	-----	7:31	7:39	7:56	8:11
	7:21	7:35	7:40	-----	7:51	8:01	8:09	8:26	8:41
	7:41	7:55	8:00	8:11	-----	8:21	8:29	8:46	9:01
	8:01	8:15	8:20	-----	8:31	8:41	8:49	9:06	9:21
	8:21	8:35	8:40	8:51	-----	9:01	9:09	9:26	9:41
	8:41	8:55	9:00	-----	9:11	9:21	9:29	9:46	10:01
	9:01	9:15	9:20	9:31	-----	9:41	9:49	10:06	10:21
	9:21	9:35	9:40	-----	9:51	10:01	10:09	10:26	10:41
	9:41	9:55	10:00	10:11	-----	10:21	10:29	10:46	11:01
	10:01	10:15	10:20	-----	10:31	10:41	10:49	11:06	11:21
	10:21	10:35	10:40	10:51	-----	11:01	11:09	11:26	11:41
	10:41	10:55	11:00	-----	11:11	11:21	11:29	11:46	<b>12:01</b>
	11:11	11:25	11:30	11:41	-----	11:51	11:59	<b>12:16</b>	<b>12:31</b>
	11:41	11:55	<b>12:00</b>	-----	<b>12:11</b>	<b>12:21</b>	<b>12:29</b>	<b>12:46</b>	<b>1:01</b>
<b>PM</b>	<b>12:11</b>	<b>12:25</b>	<b>12:30</b>	<b>12:41</b>	-----	<b>12:51</b>	<b>12:59</b>	<b>1:16</b>	<b>1:31</b>
	<b>12:41</b>	<b>12:55</b>	<b>1:00</b>	-----	<b>1:11</b>	<b>1:21</b>	<b>1:29</b>	<b>1:46</b>	<b>2:01</b>
	<b>1:11</b>	<b>1:25</b>	<b>1:30</b>	<b>1:41</b>	-----	<b>1:51</b>	<b>1:59</b>	<b>2:16</b>	<b>2:31</b>
	<b>1:41</b>	<b>1:55</b>	<b>2:00</b>	-----	<b>2:11</b>	<b>2:21</b>	<b>2:29</b>	<b>2:46</b>	<b>3:01</b>
	<b>2:01</b>	<b>2:15</b>	<b>2:20</b>	<b>2:31</b>	-----	<b>2:41</b>	<b>2:49</b>	<b>3:06</b>	<b>3:21</b>
	<b>2:21</b>	<b>2:35</b>	<b>2:40</b>	-----	<b>2:51</b>	<b>3:01</b>	<b>3:09</b>	<b>3:26</b>	<b>3:41</b>
	<b>2:41</b>	<b>2:55</b>	<b>3:00</b>	<b>3:11</b>	-----	<b>3:21</b>	<b>3:29</b>	<b>3:46</b>	<b>4:01</b>
	<b>3:01</b>	<b>3:15</b>	<b>3:20</b>	-----	<b>3:31</b>	<b>3:41</b>	<b>3:49</b>	<b>4:06</b>	<b>4:21</b>
	<b>3:21</b>	<b>3:35</b>	<b>3:40</b>	<b>3:51</b>	-----	<b>4:01</b>	<b>4:09</b>	<b>4:26</b>	<b>4:41</b>
	<b>3:41</b>	<b>3:55</b>	<b>4:00</b>	-----	<b>4:11</b>	<b>4:21</b>	<b>4:29</b>	<b>4:46</b>	<b>5:01</b>
	<b>4:01</b>	<b>4:15</b>	<b>4:20</b>	<b>4:31</b>	-----	<b>4:41</b>	<b>4:49</b>	<b>5:06</b>	<b>5:21</b>
	<b>4:21</b>	<b>4:35</b>	<b>4:40</b>	-----	<b>4:51</b>	<b>5:01</b>	<b>5:09</b>	<b>5:26</b>	<b>5:41</b>
	<b>4:41</b>	<b>4:55</b>	<b>5:00</b>	<b>5:11</b>	-----	<b>5:21</b>	<b>5:29</b>	<b>5:46</b>	<b>6:01</b>
	<b>5:01</b>	<b>5:15</b>	<b>5:20</b>	-----	<b>5:31</b>	<b>5:41</b>	<b>5:49</b>	<b>6:06</b>	<b>6:21</b>
	<b>5:31</b>	<b>5:45</b>	<b>5:50</b>	<b>6:01</b>	-----	<b>6:11</b>	<b>6:19</b>	<b>6:36</b>	<b>6:51</b>
	<b>6:01</b>	<b>6:15</b>	<b>6:20</b>	-----	<b>6:31</b>	<b>6:41</b>	<b>6:49</b>	<b>7:06</b>	<b>7:21</b>
	<b>6:31</b>	<b>6:45</b>	<b>6:50</b>	<b>7:01</b>	-----	<b>7:11</b>	<b>7:19</b>	<b>7:36</b>	<b>7:51</b>
	<b>7:01</b>	<b>7:15</b>	<b>7:20</b>	-----	<b>7:31</b>	<b>7:41</b>	<b>7:49</b>	<b>8:06</b>	<b>8:21</b>
	<b>7:31</b>	<b>7:45</b>	<b>7:50</b>	<b>8:01</b>	-----	<b>8:11</b>	<b>8:19</b>	<b>8:36</b>	<b>8:51</b>
	<b>8:01</b>	<b>8:15</b>	<b>8:20</b>	-----	<b>8:31</b>	<b>8:41</b>	<b>8:49</b>	<b>9:06</b>	<b>9:21</b>
	<b>8:31</b>	<b>8:45</b>	<b>8:50</b>	<b>9:01</b>	-----	<b>9:11</b>	<b>9:19</b>	<b>9:36</b>	<b>9:51</b>
	<b>9:01</b>	<b>9:15</b>	<b>9:20</b>	-----	<b>9:31</b>	<b>9:41</b>	<b>9:49</b>	<b>10:06</b>	<b>10:21</b>

## MONDAY – FRIDAY • INBOUND TO DOWNTOWN

	9	8	7	6	4	5	3	2	1
	Centennial Dr at Hacks Cross Rd	Hickory Ridge Mall	American Way at Perkins Rd	American Way Transit Center	Knight Arnold Rd at Julius Lewis	Kimball Ave at Highland St	Lamar Ave at S Parkway	Lamar Ave at Bellevue Blvd	Hudson Transit Center
AM	4:48	5:02	5:20	5:26	-----	5:37	5:48	5:54	6:08
	5:18	5:32	5:50	5:56	6:07	-----	6:18	6:24	6:38
	5:48	6:02	6:20	6:26	-----	6:37	6:48	6:54	7:08
	6:18	6:32	6:50	6:56	7:07	-----	7:18	7:24	7:38
	6:48	7:02	7:20	7:26	-----	7:37	7:48	7:54	8:08
	7:18	7:32	7:50	7:56	8:07	-----	8:18	8:24	8:38
	7:48	8:02	8:20	8:26	-----	8:37	8:48	8:54	9:08
	8:18	8:32	8:50	8:56	9:07	-----	9:18	9:24	9:38
	8:48	9:02	9:20	9:26	-----	9:37	9:48	9:54	10:08
	9:08	9:22	9:40	9:46	9:57	-----	10:08	10:14	10:28
	9:28	9:42	10:00	10:06	-----	10:17	10:28	10:34	10:48
	9:48	10:02	10:20	10:26	10:37	-----	10:48	10:54	11:08
	10:08	10:22	10:40	10:46	-----	10:57	11:08	11:14	11:28
	10:28	10:42	11:00	11:06	11:17	-----	11:28	11:34	11:48
	10:48	11:02	11:20	11:26	-----	11:37	11:48	11:54	12:08
	11:08	11:22	11:40	11:46	11:57	-----	12:08	12:14	12:28
11:28	11:42	12:00	12:06	-----	12:17	12:28	12:34	12:48	
11:48	12:02	12:20	12:26	12:37	-----	12:48	12:54	1:08	
PM	12:08	12:22	12:40	12:46	-----	12:57	1:08	1:14	1:28
	12:38	12:52	1:10	1:16	1:27	-----	1:38	1:44	1:58
	1:08	1:22	1:40	1:46	-----	1:57	2:08	2:14	2:28
	1:38	1:52	2:10	2:16	2:27	-----	2:38	2:44	2:58
	2:08	2:22	2:40	2:46	-----	2:57	3:08	3:14	3:28
	2:38	2:52	3:10	3:16	3:27	-----	3:38	3:44	3:58
	3:08	3:22	3:40	3:46	-----	3:57	4:08	4:14	4:28
	3:38	3:52	4:10	4:16	4:27	-----	4:38	4:44	4:58
	4:08	4:22	4:40	4:46	-----	4:57	5:08	5:14	5:28
	4:28	4:42	5:00	5:06	5:17	-----	5:28	5:34	5:48
	4:48	5:02	5:20	5:26	-----	5:37	5:48	5:54	6:08
	5:08	5:22	5:40	5:46	5:57	-----	6:08	6:14	6:28
	5:28	5:42	6:00	6:06	-----	6:17	6:28	6:34	6:48
	5:48	6:02	6:20	6:26	6:37	-----	6:48	6:54	7:08
	6:08	6:22	6:40	6:46	-----	6:57	7:08	7:14	7:28
	6:28	6:42	7:00	7:06	7:17	-----	7:28	7:34	7:48
6:48	7:02	7:20	7:26	-----	7:37	7:48	7:54	8:08	
7:08	7:22	7:40	7:46	7:57	-----	8:08	8:14	8:28	
7:28	7:42	8:00	8:06	-----	8:17	8:28	8:34	8:48	
7:58	8:12	8:30	8:36	8:47	-----	8:58	9:04	9:18	
8:28	8:42	9:00	9:06	-----	9:17	9:28	9:34	9:48	
8:58	9:12	9:30	9:36	9:47	-----	9:58	10:04	10:18	
9:28	9:42	10:00	10:06	-----	10:17	10:28	10:34	10:48	
9:58	10:12	10:30	10:36	10:47	-----	10:58	11:04	11:18	
10:28	10:42	11:00	11:06	-----	11:17	11:28	11:34	11:48	

## SATURDAY • OUTBOUND FROM DOWNTOWN

	1	2	3	4	5	6	7	8	9
	Hudson Transit Center	Lamar Ave at Bellevue Blvd	Lamar Ave at S Parkway	Knight Arnold Rd at Julius Lewis	Kimball Ave at Highland St	American Way Transit Center	American Way at Perkins Rd	Hickory Ridge Mall	Centennial Dr at Hacks Cross Rd
AM	7:21	7:35	7:40	-----	7:51	8:01	8:09	8:26	8:41
	7:51	8:05	8:10	8:21	-----	8:31	8:39	8:56	9:11
	8:21	8:35	8:40	-----	8:51	9:01	9:09	9:26	9:41
	8:51	9:05	9:10	9:21	-----	9:31	9:39	9:56	10:11
	9:21	9:35	9:40	-----	9:51	10:01	10:09	10:26	10:41
	9:51	10:05	10:10	10:21	-----	10:31	10:39	10:56	11:11
	10:21	10:35	10:40	-----	10:51	11:01	11:09	11:26	11:41
	10:51	11:05	11:10	11:21	-----	11:31	11:39	11:56	12:11
	11:21	11:35	11:40	-----	11:51	12:01	12:09	12:26	12:41
	11:51	12:05	12:10	12:21	-----	12:31	12:39	12:56	1:11
PM	12:21	12:35	12:40	-----	12:51	1:01	1:09	1:26	1:41
	12:51	1:05	1:10	1:21	-----	1:31	1:39	1:56	2:11
	1:21	1:35	1:40	-----	1:51	2:01	2:09	2:26	2:41
	1:51	2:05	2:10	2:21	-----	2:31	2:39	2:56	3:11
	2:21	2:35	2:40	-----	2:51	3:01	3:09	3:26	3:41
	2:51	3:05	3:10	3:21	-----	3:31	3:39	3:56	4:11
	3:21	3:35	3:40	-----	3:51	4:01	4:09	4:26	4:41
	3:51	4:05	4:10	4:21	-----	4:31	4:39	4:56	5:11
	4:21	4:35	4:40	-----	4:51	5:01	5:09	5:26	5:41
	4:51	5:05	5:10	5:21	-----	5:31	5:39	5:56	6:11
	5:21	5:35	5:40	-----	5:51	6:01	6:09	6:26	6:41
	5:51	6:05	6:10	6:21	-----	6:31	6:39	6:56	7:11
	6:21	6:35	6:40	-----	6:51	7:01	7:09	7:26	7:41

## SATURDAY • INBOUND TO DOWNTOWN

	9	8	7	6	5	3	2	1	
	Centennial Dr at Hacks Cross Rd	Hickory Ridge Mall	American Way at Perkins Rd	American Way Transit Center	Knight Arnold Rd at Julius Lewis	Kimball Ave at Highland St	Lamar Ave at S Parkway	Lamar Ave at Bellevue Blvd	Hudson Transit Center
AM	8:50	9:04	9:22	9:28	-----	9:39	9:50	9:56	10:10
	9:20	9:34	9:52	9:58	10:09	-----	10:20	10:26	10:40
	9:50	10:04	10:22	10:28	-----	10:39	10:50	10:56	11:10
	10:20	10:34	10:52	10:58	11:09	-----	11:20	11:26	11:40
	10:50	11:04	11:22	11:28	-----	11:39	11:50	11:56	12:10
	11:20	11:34	11:52	11:58	12:09	-----	12:20	12:26	12:40
	11:50	12:04	12:22	12:28	-----	12:39	12:50	12:56	1:10
	12:20	12:34	12:52	12:58	1:09	-----	1:20	1:26	1:40
	12:50	1:04	1:22	1:28	-----	1:39	1:50	1:56	2:10
	1:20	1:34	1:52	1:58	2:09	-----	2:20	2:26	2:40
PM	1:50	2:04	2:22	2:28	-----	2:39	2:50	2:56	3:10
	2:20	2:34	2:52	2:58	3:09	-----	3:20	3:26	3:40
	2:50	3:04	3:22	3:28	-----	3:39	3:50	3:56	4:10
	3:20	3:34	3:52	3:58	4:09	-----	4:20	4:26	4:40
	3:50	4:04	4:22	4:28	-----	4:39	4:50	4:56	5:10
	4:20	4:34	4:52	4:58	5:09	-----	5:20	5:26	5:40
	4:50	5:04	5:22	5:28	-----	5:39	5:50	5:56	6:10
	5:20	5:34	5:52	5:58	6:09	-----	6:20	6:26	6:40
	5:50	6:04	6:22	6:28	-----	6:39	6:50	6:56	7:10
	6:20	6:34	6:52	6:58	7:09	-----	7:20	7:26	7:40
	6:50	7:04	7:22	7:28	-----	7:39	7:50	7:56	8:10
	7:20	7:34	7:52	7:58	8:09	-----	8:20	8:26	8:40
	7:50	8:04	8:22	8:28	-----	8:39	8:50	8:56	9:10

## SUNDAY • OUTBOUND FROM DOWNTOWN

	1	2	3	4	5	6	7	8	9
	Hudson Transit Center	Lamar Ave at Bellevue Blvd	Lamar Ave at S Parkway	Knight Arnold Rd at Julius Lewis	Kimball Ave at Highland St	American Way Transit Center	American Way at Perkins Rd	Hickory Ridge Mall	Centennial Dr at Hacks Cross Rd
AM	8:21	8:35	8:40	-----	8:51	9:01	9:09	9:26	9:41
	8:51	9:05	9:10	9:21	-----	9:31	9:39	9:56	10:11
	9:21	9:35	9:40	-----	9:51	10:01	10:09	10:26	10:41
	9:51	10:05	10:10	10:21	-----	10:31	10:39	10:56	11:11
	10:21	10:35	10:40	-----	10:51	11:01	11:09	11:26	11:41
	10:51	11:05	11:10	11:21	-----	11:31	11:39	11:56	12:11
	11:21	11:35	11:40	-----	11:51	12:01	12:09	12:26	12:41
	11:51	12:05	12:10	12:21	-----	12:31	12:39	12:56	1:11
PM	12:21	12:35	12:40	-----	12:51	1:01	1:09	1:26	1:41
	12:51	1:05	1:10	1:21	-----	1:31	1:39	1:56	2:11
	1:21	1:35	1:40	-----	1:51	2:01	2:09	2:26	2:41
	1:51	2:05	2:10	2:21	-----	2:31	2:39	2:56	3:11
	2:21	2:35	2:40	-----	2:51	3:01	3:09	3:26	3:41
	2:51	3:05	3:10	3:21	-----	3:31	3:39	3:56	4:11
	3:21	3:35	3:40	-----	3:51	4:01	4:09	4:26	4:41
	3:51	4:05	4:10	4:21	-----	4:31	4:39	4:56	5:11

## SUNDAY • INBOUND TO DOWNTOWN

	9	8	7	6	5	3	2	1	
	Centennial Dr at Hacks Cross Rd	Hickory Ridge Mall	American Way at Perkins Rd	American Way Transit Center	Knight Arnold Rd at Julius Lewis	Kimball Ave at Highland St	Lamar Ave at S Parkway	Lamar Ave at Bellevue Blvd	Hudson Transit Center
AM	9:50	10:04	10:22	10:28	-----	10:39	10:50	10:56	11:10
	10:20	10:34	10:52	10:58	11:09	-----	11:20	11:26	11:40
	10:50	11:04	11:22	11:28	-----	11:39	11:50	11:56	12:10
	11:20	11:34	11:52	11:58	12:09	-----	12:20	12:26	12:40
	11:50	12:04	12:22	12:28	-----	12:39	12:50	12:56	1:10
PM	12:20	12:34	12:52	12:58	1:09	-----	1:20	1:26	1:40
	12:50	1:04	1:22	1:28	-----	1:39	1:50	1:56	2:10
	1:20	1:34	1:52	1:58	2:09	-----	2:20	2:26	2:40
	1:50	2:04	2:22	2:28	-----	2:39	2:50	2:56	3:10
	2:20	2:34	2:52	2:58	3:09	-----	3:20	3:26	3:40
	2:50	3:04	3:22	3:28	-----	3:39	3:50	3:56	4:10
	3:20	3:34	3:52	3:58	4:09	-----	4:20	4:26	4:40
	3:50	4:04	4:22	4:28	-----	4:39	4:50	4:56	5:10
	4:20	4:34	4:52	4:58	5:09	-----	5:20	5:26	5:40
	4:50	5:04	5:22	5:28	-----	5:39	5:50	5:56	6:10
5:20	5:34	5:52	5:58	6:09	-----	6:20	6:26	6:40	

## Instructions

- The bus stops at this location at listed times.
- Look for the column of times below the matching symbol in the schedule.
- Only certain trips operate along this portion of the route.
- See the schedule for trips that provide service here.
- The bus operates express along this portion of the route.
- Transfer point shows where this bus intersects with other routes that are available for transfer.
- The bus stops at the times listed below the numbered symbol.
- Light times are A.M.; bold times are P.M.
- The timetable shows when the bus is scheduled to depart.
- Actual departure times may vary and depend upon traffic and weather conditions.
- Arrive at the bus stop about 10 minutes early to avoid missing the bus.

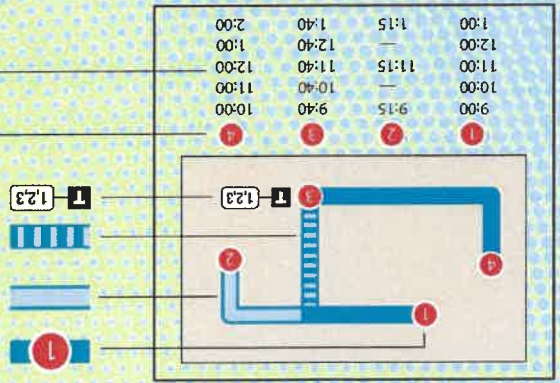

## MATA Fares

Adult Base Fare	\$1.00
*Student Base Fare	\$1.00
*Seniors/Disabled Base Fare	\$0.50
MATAplus Base Fare	\$2.00

## MULTI-RIDE PASSES

Daily FastPass	\$2.00
*Student Daily FastPass	\$2.00
*Senior/Disabled Daily FastPass	\$1.00

## \*MATA ID REQUIRED.

Seniors & people with disabilities must have a valid MATA ID for the reduced price.

Route schedules may be subject to change without notice.

## MATA Information

**Call Center & Customer Services**  
(901) 274 - MATA (6282)

**Airways Transit Center**  
3033 Airways Boulevard

**American Way Transit Center**  
3921 American Way

**Hudson Transit Center**  
444 N. Main Street

**MATA Administrative Offices**  
One Commerce Square Building  
40 S. Main Street

**MATA Operations Center**  
1370 Levee Road

Large print schedules are available upon request.  
All buses are wheelchair accessible.

Visit us at : [www.MATAtransit.com](http://www.MATAtransit.com)

EFFECTIVE : 8/13/2023

# ROUTE 36 Lamar



## SERVING

- Hickory Ridge Mall
- Excel Center
- American Way Transit Center
- Cross Creek Shopping Center
- Downtown Memphis
- Hudson Transit Center



(901) 274-6282  
[www.matatransit.com](http://www.matatransit.com)